

客户名称:

输出端

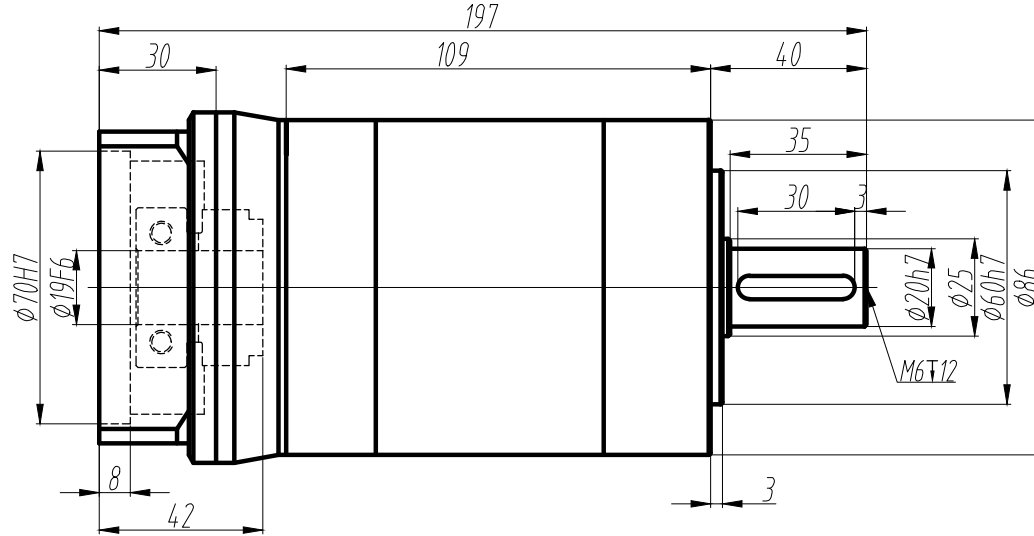

输入端

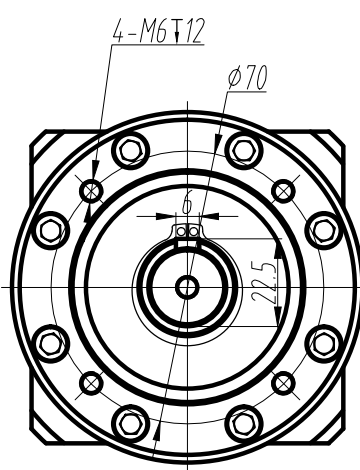
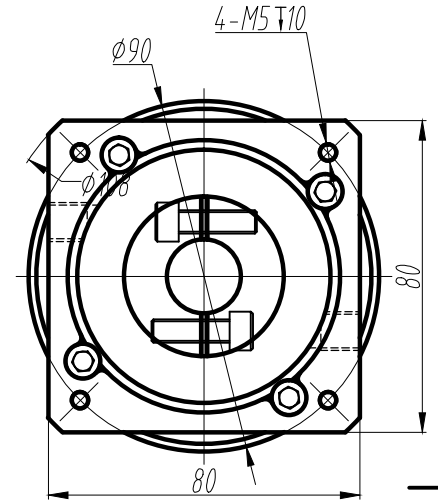

技术参数 technical parameter

额定输出转矩 Nominal torque	___Nm	最大输出转矩 Max.output torque	___Nm
额定输入转速 Rated input speed	3000rpm	最大输入转速 Max.input speed	6000rpm
最大径向力 Max.radial force	1500N	输出转速10rpm, 输出轴长1/2处为受力 Speed 10rpm,Axial length 1/2 stress	
最大轴向力 Max.axial force	1300N	输出转速10rpm, 输出轴长1/2处为受力 Speed 10rpm,Axial length 1/2 stress	
满载效率 Maximum efficiency	90%	使用温度 Operating temp	-25°~ + 90°
安装方式 Installation method	任意 arbitrarily	润滑方式 Lubrication mode	长效润滑 Permanent lubrication
重量 Weight	3.7Kg	寿命 Average life span	20000h
防护等级 Protection level	IP65	法兰精度 Flange accuracy	DIN 42955-R
标准侧隙 Standard backlash		精密侧隙 Precise backlash	
输出键标准 Key standard	圆头普通平键 Round common flat key(A)GB1096-79		
齿轮精度等级 Gear precision grade	6 GB/T10095-2008		
电机功率 Motor power	750W		
电机安装尺寸 Motor dimensions	φ19*35/φ70*3/4-φ5.5-φ90		

标准轴
Standard output shaft

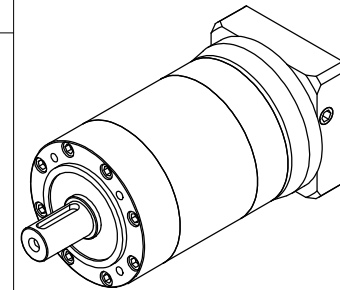
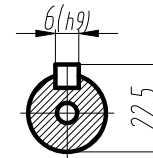

1000	58.0
700	93.0
.....
250	135.0
200	125.0
175	135.0
140	125.0
125	135.0
100	125.0
80	125.0
减速比(可选择)	额定转矩(Nm)

OPE090三級尺寸圖

OPE090-L3-()-S2-P2

标记	处数	分区	更改文件号	签名	年月日	图号:	AOPTÉ		
设计			标准化			数量	重量	比例	奧普特
审核								1:1	⊕ ⊞
工艺			批准						